

Predicted

Total Impulse	8 Newton Seconds
Average Thrust	6 Newtons
Burn Time	±1 Second
Dry Weight	40 grams
Propellant Weight	20 grams

A-A (1:1)

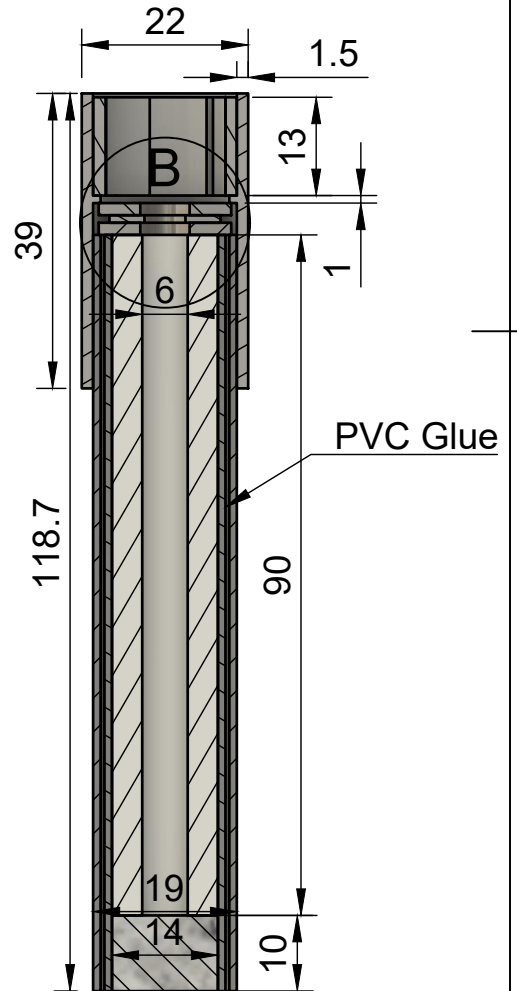

B (2:1)

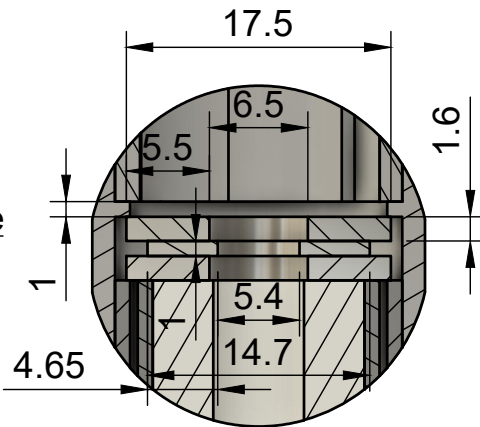
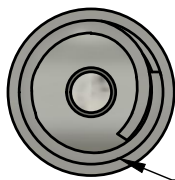

Space
(Unused)

Dept. Populsion	Technical reference Yes	Created by Denneth Ahles 04/03/2022	Approved by Nobody		
		Document type Blueprints	Document status Finished		
		Title R-n Series PM-19 Plastic Motor 19mm	DWG No. 000000000004		
		Rev. 1	Date of issue 04/03/2022	Sheet 1/1	